

DIST.	COUNTY	ROUTE	POST MILES TOTAL PROJECT	SHEET NO.	TOTAL SHEETS

Randell D. Hiatt
REGISTERED CIVIL ENGINEER

May 31, 2018
PLANS APPROVAL DATE

THE STATE OF CALIFORNIA OR ITS OFFICERS OR AGENTS SHALL NOT BE RESPONSIBLE FOR THE ACCURACY OR COMPLETENESS OF SCANNED COPIES OF THIS PLAN SHEET.

Randell D. Hiatt
REGISTERED PROFESSIONAL ENGINEER
No. C50200
Exp. 6-30-19
CIVIL
STATE OF CALIFORNIA

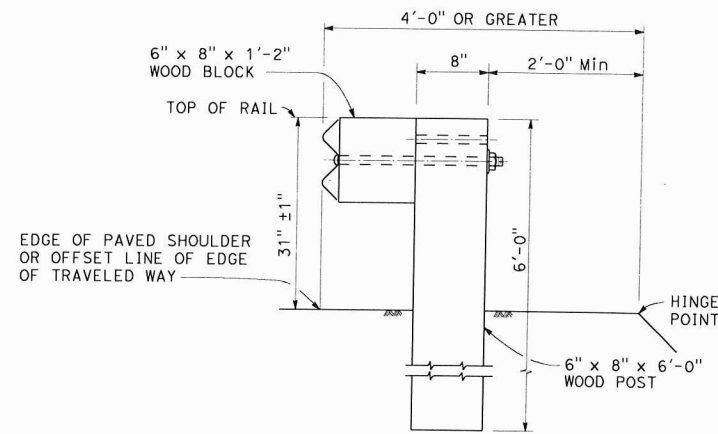

DETAIL A
TYPICAL ROADWAY
INSTALLATION
See Note 1

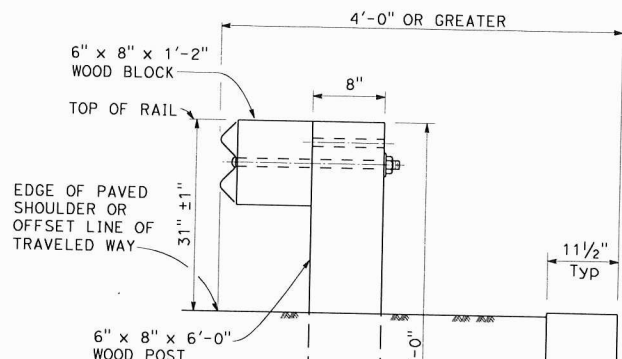

DETAIL C
INSTALLATION AT EARTH RETAINING WALLS

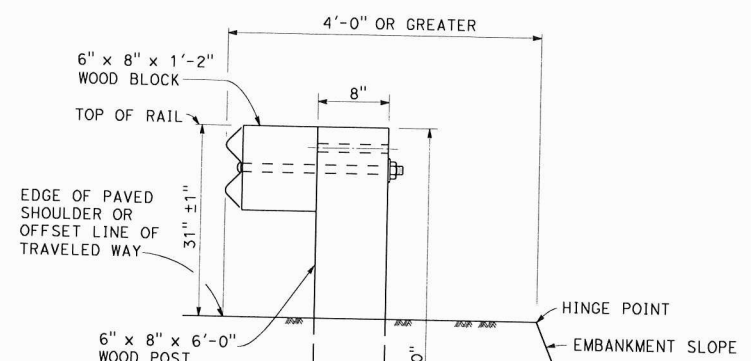

DETAIL D

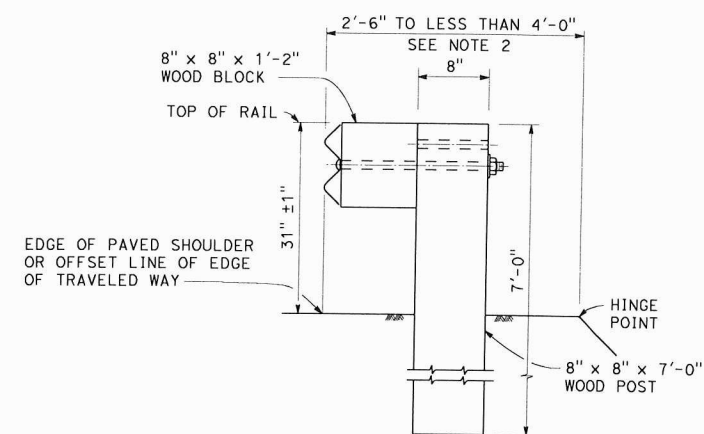

DETAIL B
NARROW ROADWAY
INSTALLATION
See Note 1

POST EMBEDMENT

- NOTES:**
1. These installation details also applicable to steel line post installations. For Detail A, C, and D, where steel line post installations are constructed, W6 x 8.5 or W6 x 9 steel post, 6'-0" in length, with 6" x 8" x 1'-2" notched wood blocks or notched recycled plastic blocks are to be used in place of the size of wood post and wood block shown. For Detail B, where steel line post installations are constructed, W6 x 8.5 or W6 x 9 steel post, 8'-0" in length, with 8" x 8" x 1'-2" notched wood blocks or notched recycled plastic blocks are to be used in place of the size of wood post and wood block shown. For additional installation details, see Standard Plans A77L1 and A77L2.
 2. Where the distance between the face of the rail and the hinge point is less than 2'-6", see the Project Plans for special details.
 3. For dike positioning with MGS installations, see Standard Plan A77N4.

STATE OF CALIFORNIA
DEPARTMENT OF TRANSPORTATION
MIDWEST GUARDRAIL SYSTEM
TYPICAL LINE POST
EMBEDMENT AND
HINGE POINT OFFSET DETAILS
NO SCALE

A77N3

2018 STANDARD PLAN A77N3

63