

CHANNEL WALL ELEVATION

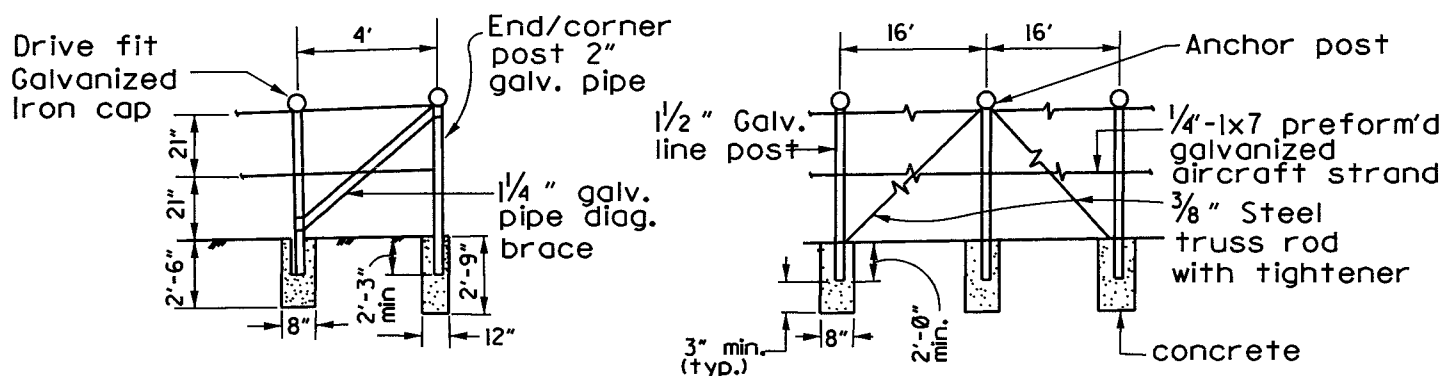

RIGHT OF WAY ELEVATION

ORANGE COUNTY RESOURCES & DEVELOPMENT MANAGEMENT DEPARTMENT

Approved

H. I. Nakasone
 H. I. Nakasone, Chief Engineer

Adopted: Res. 77-92

Revised: Res. 78-791; 91-1481; 96-546; 06-010

STD. PLAN

1413

SHT. 1 OF 2

GUARD CABLE FENCE

NOTES:

1. Ground shall be graded before fence construction begins. Localized ground depressions remaining that are more than 3 inches deep shall be eliminated by properly placing compacted fill.
2. All metal parts of fences and gates shall be galvanized new materials, and all posts shall be fitted with drive-fit caps.
3. Lightweight metal inserts shall be sheet metal tube with I.D. $\frac{3}{4}$ " greater than post O.D. Grout posts with neat grout of one part cement to two parts water or, if approved by the Engineer, with sulphur.
4. The fencing on bridges, headwalls and wingwalls shall be installed in such a manner that there are no openings or gaps which in the opinion of the Engineer could be hazardous.
5. Unless otherwise directed, construct fence with cable 0.2' inside R/W line. At R/W monuments, straddle monument with posts set 2.5' away from monument.
6. Cables shall be stretched and fastened with 2 cable clamps at each anchor post at 160 feet on center. Nuts shall be welded to clamps or covered with an epoxy putty (J.B. Weld or equal) to prevent removal.
7. Anchor posts shall be guyed with $\frac{3}{8}$ " steel truss rods as shown.
8. Pipe for fence shall conform to ASTM A-120. Galvanizing shall comply with ASTM A-123.
9. Where used for right-of-way delineation and to restrict vehicular access, the lower strand of cable may be deleted at the option of the Engineer.
10. Where used in conjunction with bicycle trails, the fence shall have sufficient reflectorized markings to be visible from a minimum of 300 feet, except where fencing is parallel to the trail.

ORANGE COUNTY RESOURCES & DEVELOPMENT MANAGEMENT DEPARTMENT

Approved

H. I. Nakasone, Chief Engineer

Adopted: Res. 77-92

Revised: Res. 78-791; 91-1481; 96-546; 06-010

STD. PLAN

1413

SHT. 2 OF 2

SPECIAL PROVISIONS - GUARD CABLE FENCE